



United States  
**Consumer Product Safety Commission**

Arthur Lee  
Electrical Engineer  
Division of Electrical Engineering and Fire Sciences  
Office of Hazard Identification and Reduction

Tel: 301-987-2008  
Email: [alee@cpsc.gov](mailto:alee@cpsc.gov)

October 20, 2023

Megan Van Heirseele  
TC Project Manager  
Underwriters Laboratories, Inc.  
333 Pfingsten Road  
Northbrook, IL 60062

Dear Ms. Heirseele:

U.S. Consumer Product Safety Commission (CPSC) staff<sup>1</sup> appreciates the opportunity to submit these proposed revisions and comments to the first edition draft for UL 2056, Standard for Safety for Power Banks for review by UL Standards & Engagement (ULSE) Technical Committee (TC) 2056. The attached document contains the tracked changes and comments to the draft. CPSC staff believes that these proposed requirements are necessary to address foreseeable consumer use of these products.

An effective standard is much needed as CPSC has recalled over 500,000 power banks in the past year.

- [Fantasia Trading Recalls Anker Power Banks Due to Fire Hazard | CPSC.gov](#)
- [VRURC Portable Chargers Recalled Due to Fire Hazard; Sold Exclusively on Amazon.com by VRURC; Caught Fire on Commercial Flight | CPSC.gov](#)
- [Costco Recalls Ubio Labs Power Banks Due to Fire Hazard; Caught Fire on Commercial Flight \(Recall Alert\) | CPSC.gov](#)

CPSC staff appreciates the work ULSE staff and the TC have put forth in developing UL 2056. As mentioned in the February 7, 2023, letter from CPSC, Health Canada, and Profeco, these three international partners are willing and interested in contributing to the development of this standard and look forward to participating in further discussions about this standard. Accordingly, CPSC staff recommends that UL withdraw the draft and allow the technical committee to address the comments and edits put forth by the CPSC staff.

---

<sup>1</sup> The views expressed in this letter are those of CPSC staff, and they have not been reviewed or approved by, and may not reflect, the views of the Commission.



United States  
**Consumer Product Safety Commission**

Arthur Lee  
Electrical Engineer  
Division of Electrical Engineering and Fire Sciences  
Office of Hazard Identification and Reduction

Tel: 301-987-2008  
Email: [alee@cpsc.gov](mailto:alee@cpsc.gov)

Sincerely,

A handwritten signature in black ink, appearing to read "Arthur Lee", written in a cursive style.

Arthur Lee  
Electrical Engineer  
Division of Electrical Engineering and Fire Sciences

CC: Jacqueline Campbell, CPSC Voluntary Standards Coordinator; Franco LaRiccia, Health Canada;  
Rafael Regla Aguirre, Profeco; Richard O'Brien, CPSC International Programs

## PROPOSAL

Underline represents new text. Strikethrough represents deleted text.

### INTRODUCTION

#### 1 Scope

These requirements cover power banks, sometimes also known as portable USB chargers or portable back-up battery power, which are standalone devices that incorporate secondary batteries for mobile powering of low voltage electronic devices.

COMMENT: The scope of these products should only apply to secondary batteries.

1.1 These requirements cover products with the following power characteristics:

a) Input:

- 1) Supplied by isolated dc power source rated maximum 60 Vdc; or
- 2) Supplied by ac mains power source, through direct plug-in construction.

b) Output: Provides dc output(s) rated maximum 60 Vdc.

1.2 These requirements are intended to reduce the risk of fire or explosion of power banks.

1.3 These requirements also cover products with integral photovoltaic cells as a power source.

1.4 These requirements do not cover products under the scope of the Standard for Portable Power Packs, UL 2743.

#### 2 Units of Measurement

2.1 Values stated without parentheses are the requirement. Values in parentheses are explanatory or approximate information.

#### 3 Components

3.1 A component of a product covered by this Standard shall:

- a) Comply with the requirements for that component as specified in this Standard;
- b) Be used in accordance with its rating(s) established for the intended conditions of use; and
- c) Be used within its established use limitations or conditions of acceptability.

3.2 A component of a product covered by this Standard is not required to comply with a specific component requirement that:

- a) Involves a feature or characteristic not required in the application of the component in the product;
- b) Is superseded by a requirement in this standard; or
- c) Is separately evaluated when forming part of another component, provided the component is used within its established ratings and limitations.

3.3 A component shall be used in accordance with its rating established for the intended conditions of use.

3.4 Specific components are incomplete in construction features or restricted in performance capabilities. Such components are intended for use only under limited conditions, such as certain temperatures not exceeding specified limits, and shall be used only under those specific conditions.

3.5 A component that is also intended to perform other functions such as overcurrent protection, ground-fault circuit-interruption, surge suppression, any other similar functions, or any combination thereof, shall comply additionally with the requirements of the applicable UL Standard(s) that cover devices that provide those functions.

3.6 This standard deals with the covered components used in accordance with CSA C22.2 No. 0.

#### **4 Referenced Publications**

4.1 Any undated reference to a code or standard appearing in the requirements of this Standard shall be interpreted as referring to the latest edition of that code or standard.

4.2 Power banks covered by this Standard shall comply with the referenced codes and standards noted in this Section as appropriate for the country where the power bank is to be used. When the power bank is intended for use in more than one country, the product shall comply with the codes and standards for all countries where it is intended to be used. Standards that are harmonized with each other are separated by a slash ( / ).

4.3 The following publications are referenced in this Standard.

CSA C22.2 No. 0, *General Requirements – Canadian Electrical Code, Part II*

CSA C22.2 No. 0.15, *Adhesive Labels*

CSA C22.2 No. 0.17, *Evaluation of Properties of Polymeric Materials*

CSA C22.2 E60730-1, *Automatic Electric Controls – Part 1: General Requirements*

CSA C22.2 No. 60691, *Thermal-Links – Requirements and Application Guide*

CSA C22.2 No. 62133-1, *Secondary Cells and Batteries Containing Alkaline or Other Non-Acid Electrolytes – Safety Requirements for Portable Sealed Secondary Cells, and for Batteries Made From Them, for Use in Portable Applications – Part 1: Nickel Systems*

CSA C22.2 No. 62133-2, *Secondary Cells and Batteries Containing Alkaline or Other Non-Acid Electrolytes – Safety Requirements for Portable Sealed Secondary Cells, and for Batteries Made From Them, for Use in Portable Applications – Part 2: Lithium Systems*

CSA C22.2 No. 62368-1, *Audio/Video, Information and Communication Technology Equipment – Part 1:*

## *Safety Requirements*

IEC 61951-2, *Secondary Cells and Batteries Containing Alkaline or Other Non-Acid Electrolytes – Secondary Sealed Cells and Batteries for Portable Applications – Part 2: Nickel-Metal Hydride*

IEC 61960-3, *Secondary Cells and Batteries Containing Alkaline or Other Non-Acid Electrolytes – Secondary Lithium Cells and Batteries for Portable Applications – Part 3: Prismatic and Cylindrical Lithium Secondary Cells, and Batteries Made from Them*

UL 248-14, *Low-Voltage Fuses – Part 14, Supplemental Fuses*

UL 310, *Electrical Quick-Connect Terminals*

UL 486A-486B, *Wire Connectors*

UL 486C, *Splicing Wire Connectors*

UL 486E, *Equipment Wiring Terminals for Use with Aluminum and/or Copper Conductors*

UL 746C, *Polymeric Materials – Use in Electrical Equipment Evaluations*

UL 796, *Printed-Wiring Boards*

UL 969, *Marking and Labeling Systems*

UL 1434, *Thermistor-Type Devices*

UL 1642, *Lithium Batteries*

UL 1977, *Component Connectors for Use in Data, Signal, Control and Power Applications*

UL 2738, *Induction Power Transmitters and Receivers for use with Low Energy Products*

UL 60691, *Thermal-Links – Requirements and Application Guide*

UL 60730-1, *Automatic Electrical Controls – Part 1: General Requirements*

UL 62133-1, *Secondary Cells and Batteries Containing Alkaline or Other Non-Acid Electrolytes – Safety Requirements for Portable Sealed Secondary Cells, and for Batteries Made From Them, for Use in Portable Applications – Part 1: Nickel Systems*

UL 62133-2, *Secondary Cells and Batteries Containing Alkaline or Other Non-Acid Electrolytes – Safety Requirements for Portable Sealed Secondary Cells, and for Batteries Made From Them, for Use in Portable Applications – Part 2: Lithium Systems*

UL 62368-1, *Audio/Video, Information and Communication Technology Equipment – Part 1: Safety Requirements*

## **5 Glossary**

5.1 For the purpose of these requirements the following definitions apply.

5.2 BATTERY – General term for (1) A single cell, or (2) a group of cells connected together either in a series and/or parallel configuration. May be ready for use or may be an installed component.

COMMENT: This term is used in the body of the standard (Definition taken from UL 1642)

~~5.2~~ 5.3 BATTERY, BUILT-IN – A single cell, or group of cells connected together either in a series and/or parallel configuration, accompanied by protecting circuit, to be installed in the power bank.

COMMENT: This follows the definition from above. A power bank can contain only one cell.

NOTE: The term “battery(ies)” refers to single or multicell batteries.

5.4 BATTERY, SECONDARY – A battery that is intended to be discharged and recharged many times in accordance with the manufacturer’s specifications.

COMMENT: Include definition for secondary battery. Definition taken from UL 1642 (last word changed to specification rather instruction)

5.5 BUILT-IN BATTERY PROTECTION CIRCUIT – [add a definition]

COMMENT: Include definition for built-in battery protection. This wording is used in the standard. Is this a protection circuit that is incorporated with the battery pack/cells (integral cell protection) or is it external of the battery pack/cells but within the power pack or can be both?

~~5.3~~ 5.6 C5 AMP RATE – The current, in amperes, that a cell or battery can be discharged at for 5 h to the voltage cutoff point specified by the manufacturer.

~~5.4~~ 5.7 CAPACITY, RATED – The capacity, in ampere-hours, of a cell or battery determined under specified load, temperature and voltage conditions and declared by the manufacturer.

~~5.5~~ 5.8 CASING – The outer rigid can or flexible pouch of an individual cell that contains the internal components of that cell.

~~5.6~~ 5.9 CELL – The basic functional electrochemical unit containing an assembly of electrodes, electrolyte, container, terminals, and usually separators, that is a source of electrical energy by direct conversion of chemical energy.

~~5.7~~ 5.10 CELL OPERATING REGION (lithium ion systems) – The range of voltage, current, and temperature in which the cell operates during charging or discharging as specified by the cell manufacturer.

~~5.8~~ 5.11 COMPONENT, CURRENT-LIMITING – Any component employed to limit current during abnormal conditions. Current-limiting components include resistors, fuses, or PTC thermistor type devices.

~~5.9~~ 5.12 COMPONENT, TEMPERATURE-LIMITING – Any component used to limit temperature during abnormal conditions. Temperature-Limiting Components include thermal protectors and thermal cutoffs.

~~5.10~~ 5.13 CURRENT, ABNORMAL CHARGING – Also called overcharge current for secondary cells; maximum rated charging current to a cell or battery under fault condition.

~~5.14~~ 5.14 DIRECT PLUG-IN CONSTRUCTION - A construction which employs a blade assembly on the enclosure for connection to the ac mains circuit.

~~5.12~~ 5.15 DISCHARGE, FORCED – Subsequent discharge of one fully discharged cell in each parallel string by connecting in series with fresh cells of the same kind so as to drive the cell into polarity reversal.

~~5.13~~ 5.16 DISCHARGED, FULLY – A condition of battery energy potential representing depletion to its end-point- voltage as specified by the manufacturer.

~~5.14~~ 5.17 ENCLOSURE – The outer housing of a power bank that provides mechanical protection and a level of fire protection for internal cells and components of the power bank.

~~5.15~~ 5.18 EXPLOSION – A condition that occurs when a cell container or power bank enclosure violently opens and major components are forcibly expelled.

~~5.16~~ 5.19 PORTABLE – Easy to be moved or carried by hand.

~~5.17~~ 5.20 POWER BANK - Also known as portable USB chargers or portable back-up battery power. A standalone, portable power supply with built-in lithium or nickel battery and dc/dc converter circuitry for mobile use of powering electronic devices through USB or similar universal interfaces.

~~5.18~~ UPPER LIMIT CHARGING VOLTAGE (lithium ion systems) – The highest charging voltage at specified temperatures in the cell operating region specified by the cell manufacturer. This value is specified by the cell manufacturer and although it is a maximum limit, it may be lower than the maximum charging voltage parameter specified for the abnormal charging test.

COMMENT: Moved to list alphabetical order

~~5.19~~ 5.21 PROTECTIVE DEVICES – Any device such as a field effect transistor (FET), fuse, diode or current limiter which stops the current flow, blocks the current flow in one direction or limits the current flow in an electrical circuit.

~~5.20~~ 5.22 SHORT CIRCUIT – A direct connection between positive and negative terminals of a cell or power bank that provides a virtual zero resistance path for current flow.

5.23 UPPER LIMIT CHARGING VOLTAGE (lithium ion systems) – The highest charging voltage at specified temperatures in the cell operating region specified by the cell manufacturer. This value is specified by the cell manufacturer and although it is a maximum limit, it may be lower than the maximum charging voltage parameter specified for the abnormal charging test.

~~5.21~~ 5.24 VENTING or VENT(S) – A condition that occurs when the cell releases excessive internal pressure in a manner intended by design to preclude rupture, explosion or self-ignition.

~~5.22~~ 5.25 VOLTAGE, ABNORMAL CHARGING – Maximum specified charger output voltage applied to a cell or battery under fault condition.

## CONSTRUCTION

### 6 General

#### 6.1 Casing and enclosure

6.1.1 The enclosure of a power bank shall have the strength and rigidity required to resist the reasonably foreseeable possible abuses, that it is exposed to during its reasonably foreseeable intended use, in order to reduce the risk of fire or injury to persons.

COMMENT: Consider "reasonably foreseeable" rather than "possible." 6.1.1 supports the proposed flexing test

6.1.2 The enclosure of a power bank shall be rigid enough to prevent flexing that would result in damage to the cells or internal protective components. A tool providing the mechanical advantage of a plier ~~pliers~~, hacksaw, or similar tool, shall be the minimum mechanical capability required to open the power bank enclosure.

6.1.3 For a power bank with a plastic outer enclosure, the outer enclosure shall be designed such that it is not capable of being opened using simple tools, such as a screwdriver. The enclosure shall be ultrasonically welded, or permanently secured by equivalent means. Adhesives complying with the adhesive requirements of UL 746C or CSA C22.2 No. 0.17

Exception: For power banks rated over 50,000 mAh, single use or tamper-proof screws shall be permitted and are considered equivalent means for securing the enclosure.

COMMENT: Power banks 50,000 mAh or less should not be permitted to use any types of screws to secure the housing to prevent consumers from servicing these devices. Tamper resistant bits are readily available online. Larger power banks, such as over 50,000 mAh, may require screws to secure the housing together.

6.1.4 ~~The~~ All outer enclosure material of the power bank shall be classed as V-1 or less flammable in the minimum part thickness in accordance with UL 746C or CSA C22.2 No. 0.17.

Exception: Materials are not required to be classed as V-1 or less flammable when they comply with the Enclosure Flammability – 20 mm (3/4 inch) Flame test described in UL 746C or CSA C22.2 No. 0.17.

6.1.5 Nonmetallic materials used for internal parts within the overall enclosure shall be rated V-2 minimum.

6.1.6 ~~Small parts, and~~ Gaskets, that are not located near live parts, and are located in a manner such that they cannot propagate flame from one area to another within the equipment, are not required to have a specific flame rating.

COMMENT: Small parts is not defined and subjective. Consider removing or adding a definition for small parts.

6.1.7 No openings in power bank enclosures shall be permitted to prevent damage to cells, connections, and internal circuitry and shorting of electrical spacings within the pack. ~~Enclosure openings shall not be located over cells that do not comply with the rigid casing requirements of 6.1.2 or over protective circuitry and connections where damage or shorting from debris entering the enclosure could result in a hazard.~~



COMMENT: Moved as an exception. This exception is subjective "where damage or shorting from debris entering the enclosure shall not result in a hazard" - consider rewording.

Exception: Openings for power input/ output and pressure venting are permitted. Enclosure openings are permitted to be located over cells that comply with the rigid casing requirements of 6.1.2 or over protective circuitry and connections where damage or shorting from debris entering the enclosure shall not result in a hazard.

## 6.2 Cells

6.2.1 The lithium cell of a power bank shall comply with either UL 1642 or UL 62133-2 / CSA C22.2 No. 62133-2.

6.2.2 The nickel cell of a power bank shall comply with either UL 2054 or UL 62133-1 / CSA C22.2 No. 62133-1.

6.2.3 For other chemistry of cell types, the cell shall comply with the related safety standard requirements.

## 6.3 Wiring and terminals

6.3.1 Wiring shall be insulated and acceptable for the purpose, when considered with respect to temperature, current, and voltage to which the wiring is likely to be subjected within the power bank.

6.3.2 ~~The All~~ wiring splice or connections shall be mechanically secured and shall provide electrical contact without strain on connections and terminals. Wiring shall be secured and routed away from sharp edges or other parts that may compromise wiring insulation.

6.3.3 Wiring splices shall not be permitted for power banks rated.

COMMENT: Power banks that are less than 50,000 mAh do not need or should have wire splices. The wiring should be continuous and run directly between the cells, BMS, and circuit board, thus minimizing the chances for faults. Larger power banks may contain multi-purpose features that may require splices, which should be approved.

Exception: For power banks rated over 50,000 mAh, wire splices or connection are permitted.

6.3.4 All electrical connections, such as splicing wire connectors, quick-connect terminals, terminal connectors, multi-pin and other forms of wire connectors, shall comply with the following standards:

- a) The Standard for Electrical Quick-Connect Terminals, UL 310;
- b) The Standard for Wire Connectors, UL 486A-486B;
- c) The Standard for Splicing Wire Connectors, UL 486C;
- d) The Standard for Equipment Wiring Terminals for Use with Aluminum and/or Copper Conductors, UL 486E; or
- e) The Standard for Component Connectors for Use in Data, Signal, Control and Power Applications, UL 1977.

Exception: This requirement is not applicable to the following types of connections:

- a) Brazed or welded connections;
- b) Soldered connections on printed circuit boards.

c) Connections on small components that are mounted on printed circuit boards located in a low-voltage circuit.

#### 6.4 External power bank connectors

6.4.1 An external power bank connector shall be constructed to prevent inadvertent short circuiting of its terminals unless the power bank meets the limited power source requirements of the Limited Power Source Test, Section 15. Examples of methods to prevent inadvertent short-circuiting include recessing the terminals, providing circuitry that prevents inadvertent short circuiting, providing covers over the terminals, use of keyed connectors, and the like.

6.4.2 Insulating material for external power bank connectors, outside the enclosure, shall have a V-2 minimum flame rating unless the power bank meets the limited power source requirements of the Limited Power Source Test, Section 15. External connectors forming part of the fire enclosure shall be V-1 minimum.

#### 6.5 Printed wiring boards

6.5.1 Printed wiring boards with or without mounting circuit components shall be rated V-1 minimum and comply with UL 796.

COMMENT: This considers if a manufacturer decides to use a wiring board as a means to distribute power (no circuit components on the board), thus the board should be rated.

#### 6.6 Lithium Ion Systems Only

6.6.1 The voltage and temperature of each cell or each cellblock consisting of parallel-connected plural cells should not exceed the upper limit charging voltage and temperature specified by the cell manufacturer.

COMMENT: The upper temperature limits should not be exceeded for lithium ion cells as specified by the manufacturer of the cells

6.6.2 For the power bank consisting of a single cell or a single cellblock, it should be confirmed that the charging voltage and temperature of the cell does not exceed the upper limit charging voltage and temperature specified by the cell manufacturer.

6.6.3 For the power bank consisting of series-connected plural single cells or series-connected plural cellblocks, it should be confirmed that the voltages and temperatures of any one of the single cells or single cellblocks do not exceed the upper limit charging voltage and temperature, specified by the cell manufacturer, by monitoring the voltage and temperature of every single cell or the single cellblocks.

6.6.4 Compliance for 6.6.1 – 6.6.3 can be achieved through analysis of the battery protection circuit or if unable to determine through analysis, then through monitoring values during the test of Section 16.

COMMENT: If the battery protection circuit monitors the cell temperature, then this can be accomplished otherwise the temperatures would have to be verified in Section 16.

## 6.7 Direct Plug-In Construction

6.7.1 For power banks with direct plug-in construction, the following shall be met:

- a) The power bank and its built-in ac/dc power supply shall comply with the applicable requirements of UL 62368-1 / CSA C22.2 No. 62368-1.
- b) A barrier shall be provided between the built-in ac/dc power supply and built-in battery pack. The barrier shall comply with the requirements of electrical insulation and fire enclosure of UL 62368-1 / CSA C22.2 No. 62368-1.
- c) When the power bank is charged by an ac power source, the power bank shall not discharge.

## 6.8 Wireless Charging And Discharging Function

6.8.1 The power bank that provides wireless charging or wireless discharging functions shall comply with the applicable requirements of UL 2738 or similar.

## PERFORMANCE

### 7 General

7.1 Power banks are to be tested as described in Sections 11 – 25 and as follows:

- a) Section 14, Forced-Discharge Test, is applicable only to power banks with cells in multicell series applications; and
- b) Section 15, Limited Power Source Test, is an optional requirement only carried out upon manufacturer's request.

7.2 Power banks or their cells shall not explode or catch fire as a result of the tests in this Standard. For the Steady Uniform Force Test, Section 22 and the Drop Impact Test, Section 25, the samples shall also not separate or open. For the Steady Uniform Force Test, Section 22, Flexing Force Test, Section 23, Mold Stress Relief Test, Section 24 23, and the Drop Impact Test, Section 25 24, the samples shall also not vent or leak. For these tests, unacceptable leakage is deemed to have occurred when the resulting mass loss exceeds 0.1 %.

7.3 Certain end product devices require that the power output of a power bank be limited. The Limited Power Source Test described in Section 15 is to be used to determine whether a power bank is suitable in such applications where fire hazards may otherwise exist.

7.4 Each output port shall be an ES1 energy source in accordance with UL 62368-1 / CSA C22.2 No. 62368-1.

### 7.5 Protective devices

7.5.1 When a current-limiting component or temperature-limiting component that has been evaluated for the purpose (i.e. a positive temperature coefficient device complying with the tests specified in UL 1434 and UL 60730-1 or CSA C22.2 E60730-1, the Annex for Requirements for Thermistor Elements and Controls Using Thermistors, Annex J) activates as designed, testing shall be resumed as follows:

- a) An auto-resettable device that operates during the test – The test is to be continued allowing the device to cycle during the test;
- b) A manual resettable device that operates during the test – The device is to be manually reset during the test and the testing is to be continued with manually resetting the device during the test;

COMMENT: This allows manual and auto resettable device to be tested accordingly

- c) A non-resettable device or resettable device that operates during the test but does not reset – The test is to be repeated with the battery pack connected to the maximum load that does not cause the protective device to trip; and
- d) A current-limiting or temperature-limiting device that has not been evaluated for the purpose is to be shorted or bypassed from the circuit prior to testing.

## 8 Samples

8.1 Unless otherwise indicated, fresh power banks in the fully charged state are to be used for the tests. The test program and number of samples to be used in each test is shown in Table 8.1.

**Table 8.1**  
**Testing required for power banks**

Test	Section	Number of fully charged packs
<b>Electrical Tests</b>		
Short-Circuit	11	
at room temp.		5 (unsealed)
at 55 °C (131 °F)		5 (unsealed)
Abnormal Charging	12	5 (unsealed)
Abusive Overcharge	13	5 (unsealed)
Forced-Discharge <sup>a</sup>	14	5 (unsealed)
Limited Power Source	15	6 (unsealed)
Temperature	16	2 (unsealed)
Power Input	17	1 (complete)
Overload of Output Ports	18	1 (complete)
Flammability of Photovoltaic Cells	19	1 (complete)
Capacity Verification	20	1 (complete)

<b>Enclosure Tests</b>		
Steady <u>Uniform</u> Force	22	3 (complete)
<u>Flexing</u> Force	<u>23</u>	<u>2 ( complete)</u>
Mold Stress Relief	<u>24</u> <del>23</del>	3 (complete)
Drop Impact	<u>25</u> <del>24</del>	3 (complete)
Enclosure Flammability <sup>b</sup>	6	3 (+3, if necessary) unsealed enclosures
<b>Miscellaneous Tests</b>		
Label Permanence	<u>26</u> <del>25</del>	1 (complete)
<p>NOTE – Unsealed refers to power banks which do not use securement such as adhesive and/or ultrasonic welding to seal the top and bottom enclosures in order to facilitate access to the inside of the power bank. Complete refers to a whole sample of the power bank representative of production.</p> <p><sup>a</sup> Forced Discharge test is conducted only for multi-cell series configurations.</p> <p><sup>b</sup> Enclosure materials classified as V-1 or less flammable in the minimum part thickness do not require enclosure flammability tests.</p>		

8.2 All power banks shall be fully charged in accordance with the manufacturer's specifications prior to testing except for the samples to be subjected to the Abnormal Charging and Abusive Overcharge Tests, which shall be discharged to the manufacturer specified end point voltage using the manufacturer specified current prior to testing.

## 9 Important Test Considerations

9.1 As some power banks explode in the tests, it is important that personnel be protected from the flying fragments, explosive force, sudden release of heat, chemical burns, and noise results from such explosions. The test area is to be well ventilated to protect personnel from possible harmful fumes or gases.

9.2 The temperatures on the surface of the cell casings shall be monitored during the tests described in Sections 11, 12, 13, 14, 16 and 18. All personnel involved in the testing of power banks are to be instructed never to approach a sample until the surface temperature returns to ambient temperature.

## 10 Temperature Measurements

10.1 Temperatures are to be measured by thermocouples consisting of wires not larger than 24 AWG (0.21 mm<sup>2</sup>) and not smaller than 30 AWG (0.05 mm<sup>2</sup>) and a potentiometer-type instrument.

10.2 The temperature measurements on the power bank are to be made with the measuring junction of the thermocouple held tightly against the outer enclosure of the power bank.

## ELECTRICAL TESTS

### 11 Short-Circuit of Output Port Test

COMMENT: Is the intent to short the power bank output terminals or just the built-in battery? It is unclear. Edited as if to short the power bank output terminals.

11.1 Each fully charged test sample power bank, in turn, is to be short-circuited by connecting the positive and negative output port terminals of the power bank with a circuit load having a resistance load of  $80 \pm 20 \text{ m}\Omega$ . The temperature of the internal cell casing is to be monitored during the test. The power bank is to discharge until a fire or explosion is obtained, or until it is completely discharged and/or the cell case temperature has returned to  $\pm 5 \text{ }^\circ\text{C}$  ( $\pm 9 \text{ }^\circ\text{F}$ ) of ambient temperature.

11.2 Tests are to be conducted at ambient temperatures of  $20 \pm 5 \text{ }^\circ\text{C}$  ( $68 \pm 9 \text{ }^\circ\text{F}$ ) and at  $55 \pm 5 \text{ }^\circ\text{C}$  ( $131 \pm 9 \text{ }^\circ\text{F}$ ). The power banks are to reach equilibrium at  $20 \pm 5 \text{ }^\circ\text{C}$  ( $68 \pm 9 \text{ }^\circ\text{F}$ ) or  $55 \pm 5 \text{ }^\circ\text{C}$  ( $131 \pm 9 \text{ }^\circ\text{F}$ ), as applicable, before the output terminals are connected. During the tests, the cell casing temperatures shall not exceed an elevated temperature of  $20 \pm 1 \text{ }^\circ\text{C}$  ( $68 \pm 2 \text{ }^\circ\text{F}$ ) above the ambient temperature.

COMMENT: Above 75 degrees C increases the risk of progressing into a thermal runaway condition. The power bank protective circuit should limit cell heating during these tests.

11.3 Power bank constructions are to be subjected to a single fault across any protective device in the load circuit of the power bank under test. When protective devices actuate during the test, the test shall be repeated with the power bank connected to the maximum load that does not cause the protective devices to open. See 5.19.

*Exception: A positive temperature coefficient device which complies with the tests specified in UL 1434, CSA C22.2 E60730-1 or UL 60730-1, or other protective devices determined to be reliable, may remain in the circuit without being faulted. See 5.19. Other standards that may apply are UL 248-14 / CSA C22.2 No. 248.14 and UL 60691 or CSA C22.2 No. 60691.*

11.4 One of the above five test sample power banks, tested at ambient temperature of  $20 \pm 5 \text{ }^\circ\text{C}$  ( $68 \pm 9 \text{ }^\circ\text{F}$ ) shall be evaluated with the following additional conditions in place. The output terminals are to be subjected to a short circuit condition with a resistance that is capable of withstanding the short-circuit current and creating a short-circuit condition with a total external resistance of  $80 \pm 20 \text{ m}\Omega$ . The test is to be conducted on a tissue paper covered soft wood surface and the sample power bank and bare conductor are to be covered with a single layer of cheesecloth.

11.5 For all samples tested, the samples shall not vent, explode or catch fire and the tests shall not result in chemical leaks caused by cracking, rupturing or bursting of the cell casing. The temperature of the internal cell casings shall not exceed  ~~$150 \text{ }^\circ\text{C}$  ( $302 \text{ }^\circ\text{F}$ )~~  $75 \pm 1 \text{ }^\circ\text{C}$  ( $167 \pm 2 \text{ }^\circ\text{F}$ ) for lithium chemistries. For power bank samples tested in accordance with 11.4, there shall be no charring or burning of the cheesecloth or tissue paper. Charring is defined as a blackening of the cheesecloth caused by combustion. Discoloration of the cheesecloth caused by smoke is acceptable.

COMMENT: Above 75 degrees C (cell casing) increases the risk of progressing into a thermal runaway condition. The power bank protective circuit should limit cell output, thus cell heating during these tests.

## 12 Abnormal Charging of the Battery Test

12.1 The power banks are to be tested in an ambient temperature of  $20 \pm 5 \text{ }^\circ\text{C}$  ( $68 \pm 9 \text{ }^\circ\text{F}$ ). A thermocouple is to be attached to the cells of each test sample power bank. Each power bank shall be discharged at a constant current of  $0.2\text{C}/1 \text{ h}$ , to a manufacturer specified discharge endpoint voltage.

12.2 Each test sample power bank is to be subjected to the following ~~overcharge~~ abnormal charging conditions, in sequential order.

a) The test is to be conducted at the input point of the protecting circuit that accompanies the built-in battery ~~protecting circuit~~. This means input dc/dc converter circuitry of the power bank is to be bypassed to result in ~~battery overcharging, which is required for the evaluation of the protective circuitry~~ for the battery.

COMMENT: This clarifies what and where the testing input occurs. It is consistent with the wording in the definition for built-in batteries

b) The built-in battery is to be initially charged at the input point (a) using a constant current charging mode with an abnormal charging current limit of three times the maximum current  $I_c$ , specified by the manufacturer until the maximum specified abnormal charging voltage is reached. At that point, the built-in battery is to be charged with a constant maximum specified abnormal charging voltage and an abnormal charging current limit of three times the battery maximum current  $I_c$ . Charging duration is the time required to reach the manufacturer's specified end-of-charge conditions (voltage and current) plus seven additional hours. The temperature on the cell casing shall be monitored. A re-settable protective device such as a PTC that actuates during the test shall be allowed to reset and the test shall be resumed, cycling as often as necessary, but no less than 10 times, to complete the test. Automatic reset devices are allowed to cycle during the test. When an overcurrent protective device operates during the test, the test is repeated with the same charging time, but with the battery connected to the maximum load that does not cause the protective devices to operate.

COMMENT: "maximum specified abnormal charging voltage " Where is this voltage specified? By the manufacturer? The current is specified by the manufacturer.

NOTE: The current of three times the maximum current  $I_c$  calculation is based on the maximum current of built-in battery, not the maximum current of power bank.

c) The charge condition in accordance with (a) shall be conducted with each single component fault that is likely to occur in the charging circuit and which would result in overcharging of the built-in battery.

*Exception No 1: A protective device determined to be reliable may remain in the circuit without being faulted. See 7.5.1 and 5.19.*

*Exception No. 2: For built-in batteries without protective devices, the overcharge condition(s) in 12.2 item (c) shall be at the input dc/dc converter circuitry of the power bank ~~do not apply~~.*

12.3 During the test, the temperature of the cell casings shall not exceed  $75 \pm 1 \text{ }^\circ\text{C}$  ( $167 \pm 2 \text{ }^\circ\text{F}$ ) for lithium chemistries.

COMMENT: Above 75 degrees C increases the risk of progressing into a thermal runaway condition. The power bank protective circuit should limit cell output, thus cell heating during these tests.

~~12.3~~ 12.4 The samples shall not vent, explode or catch fire. For power bank samples, tests shall not result in chemical leaks caused by cracking, rupturing or bursting of the cell casing.

### 13 Abusive Overcharge of the Battery Test

13.1 The power banks are to be tested in an ambient temperature of  $20 \pm 5$  °C ( $68 \pm 9$  °F).

13.2 The tests is are to be conducted at the input point of the protecting circuit that accompanies the built-in battery protecting circuit. This means input dc/dc converter circuitry of the power bank is to be bypassed to evaluate the protection result in battery overcharging, which is required for the evaluation of protecting circuit for the built-in battery.

COMMENT: This clarifies what and where the testing input occurs. It follows the wording in the definition for built-in batteries. If charging through the protective devices for the battery, the cells should not vent if the circuit properly limited the over current and voltage.

COMMENT: "input dc/dc converter circuitry" Does the wording or testing consider AC direct plug-in units?

13.3 The built-in batteries are to be subjected to a constant charging current at the input point 13.2 at 10 times the C5 amp rate, using a supply voltage sufficient to maintain the 10 times C5 amp rate throughout the duration of the test. During the test, the temperature is to be measured on the internal cell casing of each sample. The test is to continue until the cell or battery explodes, vents, or a single operation protective device operates, and the temperature of the internal cell casing reaches steady state conditions or returns to ambient. The temperature of the cell casings shall not exceed  $75 \pm 1$  °C ( $167 \pm 2$  °F). If a PTC or other re-settable protection device operates during the test, it is to be reset a minimum of 10 times during the test. An automatic reset device is allowed to cycle during the test.

COMMENT: The protective device or circuit should limit the over current and over voltage to prevent the cells from reaching 75C to prevent a thermal runaway condition.

13.4 During the tests, batteries supplied with protective devices shall be subjected to a single component fault using any single fault condition which is likely to occur in the charging circuit and which would result in overcharging of the battery.

*Exception No 1: Protective devices determined to be reliable, may remain in the circuit without being faulted.*

COMMENT: "Protective devices determined to be reliable" sound subjective. Can this point towards other UL standards to determine they are reliable?

*Exception No. 2: For batteries without built-in protective devices, the abusive overcharge condition(s) in 13.2 shall be at the input dc/dc converter circuitry of the power bank.*

13.5 The samples shall not explode or catch fire.

13.6 At least one of the five samples shall be subjected to the test outlined in 13.3 and 13.4 with a constant current charge 5 times the C5 amp rate (e.g. at the C rate) with a supply voltage sufficient to maintain that rate throughout the duration of the test.

### 14 Forced-Discharge of the Cells Test



14.1 This test is intended for power banks with cells in multicell series applications cells that are to be used in multicell applications. The power banks are to be tested in an ambient temperature of  $20 \pm 5$  °C ( $68 \pm 9$  °F).

COMMENT: "that are to be used in multicell applications" This appears to be duplicate statement of "cells in multicell series applications cells." What part of the power bank is this supposed to apply to?

14.2 For multi-cell series configurations without parallel strings, a fully discharged cell is to be force-discharged by connecting it in series with fully charged cells of the same kind. The number of fully charged cells to be connected in series with the discharged cell is to equal the total number of cells in the pack less one.

COMMENT: In the pack are the discharged and charged cells for multi-cell series configurations without parallel strings connected – in what order are the cells to be connected? Half charged and the other half discharged? Mixed or alternating charged and discharged? Clarify and consider a figure.

14.3 For multi-cell series configurations with parallel strings, a fully discharged parallel string is to be force-discharged by connecting it in series with fully charged cells of the same kind. The number of fully charged cells to be connected in series with the discharged parallel string is to equal the total number of cells in the pack less the number of cells in the discharged parallel string.

COMMENT: In the pack are the discharged and charged cells for multi-cell series configurations with parallel strings connected – in what order are the cells to be connected? Half charged and the other half discharged? Mixed or alternating charged and discharged? Clarify and consider a figure.

14.4 Each of the five power banks shall be prepared as described in 14.2 or 14.3, as applicable.

14.5 Once the fully discharged cells (or string of cells) are connected in series with the specified number of fully charged cells, the resultant battery is to be short circuited.

14.6 The positive and negative terminals of the sample are to be connected with a copper wire with a resistance load of  $80 \pm 20$  mΩ. The power bank is to discharge until a fire or explosion is obtained, or until it has reached a completely discharged state and the cell case temperature has returned to  $\pm 10$  °C ( $\pm 18$  °F) of ambient temperature.

14.7 During the tests, power banks supplied with protective devices shall be subjected to a single component fault using any single fault condition which is likely to occur in the discharge circuit and which would result in excessive discharge of the battery.

*Exception: A positive temperature coefficient device which complies with the applicable tests specified in UL 1434 and UL 60730-1 or CSA C22.2 E60730-1, or other protective devices determined to be reliable, may remain in the circuit without being faulted. Other standards that may apply are UL 248-14 / CSA C22.2 No. 248.14 and UL 60691 or CSA C22.2 No. 60691.*

14.8 The samples shall not vent, explode or catch fire.

## 15 Limited Power Source Test

15.1 The power bank output ports are to be tested in an ambient temperature of  $20 \pm 5$  °C ( $68 \pm 9$  °F).

COMMENT: Do not understand what is the intent of LPS section. Does this section only apply to power banks with limited power source? Shouldn't all power banks have limited output? Shouldn't all LPS have overcurrent protection?

15.2 A power bank output port intended to be a limited power source shall comply with one of the following:

- a) The output is inherently limited in compliance with Table 15.1;
- b) A linear or nonlinear impedance limits the output in compliance with Table 15.1. If a positive temperature coefficient device is used, it shall:
  - 1) Comply with UL 1434;
  - 2) Pass the tests specified in the Manufacturing Deviation and Drift Section, the Endurance Section, and the Manufacturing Deviation and Drift Section and the Endurance Section in the Annex for Requirements for Controls Using Thermistors of UL 60730-1 or CSA C22.2 E60730-1; or
  - 3) Meet the requirements in UL 60730-1 or CSA C22.2 E60730-1 for a device for Type 2.AL Action;
- c) A regulating network or an integrated circuit (IC) current limiter, limits the output in compliance with Table 15.1, both under normal operating conditions and after any simulated single fault in the regulating network or IC current limiter (open circuit or short circuit); or
- d) An overcurrent protective device is used and the output is limited in compliance with Table 15.2.

**Table 15.1**  
**Limits for Power Sources Without an Overcurrent Protective Device**

Output voltage $U_{oc}$ <sup>a</sup> $V_{dc}$	Output current $I_{sc}$ <sup>b, d</sup> A	Apparent power $S$ <sup>c, d</sup> VA
$U_{oc} \leq 30$	$\leq 8.0$	$\leq 100$
$30 < U_{oc} \leq 60$	$\leq 150/U_{oc}$	$\leq 100$

<sup>a</sup>  $U_{oc}$  – Open circuit voltage with all load circuits disconnected.

<sup>b</sup>  $I_{sc}$  – Maximum output current with any non-capacitive load, including a short circuit.

<sup>c</sup>  $S(VA)$  – Maximum output VA with any non-capacitive load including short circuit.

<sup>d</sup> Measurement of  $I_{sc}$  and  $S$  are made 5 s after application of the load if protection is by an electronic circuit or a positive temperature coefficient device, and 60 s in other cases. If multiple protections are provided, such as combination of electronic circuit and positive temperature coefficient device,  $I_{sc}$  and  $S$  are measured 60 s after the application of the load with or without single fault condition applied.

**Table 15.2**  
**Limits for Power Sources With an Overcurrent Protective Device**

Output voltage $U_{oc}$ <sup>a</sup> $V_{dc}$	Output current $I_{sc}$ <sup>b, d</sup> A	Apparent power $S$ <sup>c, d</sup> VA	Current rating of overcurrent protective device <sup>e</sup> A
$\leq 20$			$\leq 5$
$20 < U_{oc} \leq 30$	$\leq 1000/U_{oc}$	$\leq 250$	$\leq 100/U_{oc}$
$30 < U_{oc} \leq 60$			$\leq 100/U_{oc}$

<sup>a</sup>  $U_{oc}$  – Open circuit voltage with all load circuits disconnected.

<sup>b</sup>  $I_{sc}$  – Maximum output current with any non-capacitive load, including a short circuit, measured 60 s after application of the load.

<sup>c</sup>  $S(VA)$  – Maximum output VA after 60 s of operation with any non-capacitive load including short circuit.

<sup>d</sup> Current limiting impedances remain in the circuit during measurement, but overcurrent protective devices are bypassed.

Output voltage $U_{oc}$ <sup>a</sup> $V_{dc}$	Output current $I_{sc}$ <sup>b, d</sup> A	Apparent power $S$ <sup>c, d</sup> VA	Current rating of overcurrent protective device <sup>e</sup> A
--	--	--	---

<sup>e</sup> The current ratings of overcurrent protective devices are based on fuses and circuit breakers that break the circuit within 120 s with a current equal to 210 % of the current rating specified in the table.

NOTE – The reason for making measurements with overcurrent protective devices bypassed is to determine the amount of energy that is available to cause possible overheating during the operating time of the overcurrent protective devices.

15.3 Where an overcurrent protective device is used, it shall be a fuse or a non-adjustable, non-auto reset, electromechanical device.

15.4 The built-in battery of for the power bank shall be fully charged when conducting the measurements for  $U_{oc}$ ,  $I_{sc}$ , and  $S$  according to Table 15.1 and Table 15.2.

15.5 The non-capacitive load referenced in Table 15.1 and Table 15.2 shall be adjusted to develop maximum measured values of current ( $I_{sc}$ ) and power ( $S$ ) that can be obtained over the time limits noted in Table 15.1 and Table 15.2. Simulated faults in a regulating network required according to 15.2(c) above are applied under these load conditions.

15.6 Power banks that meet the limited power source requirements may be marked "Limited Power Source" "LPS" to indicate that they are considered to be a limited power source. Power banks that do not meet these requirements, regardless of terminal design, shall not be marked to indicate that they are a limited power source and are restricted to applications where a limited power source is not required.

COMMENT: "Power banks that do not meet these requirements" Please clarify on when it doesn't meet the LPS requirements. It seems if it does not meet the LPS requirements and fails, it should meet the other requirements of the standard and cannot be labeled as LPS.

## 16 Temperature Test

16.1 A power bank shall be subjected to a normal temperature test under both input (charging) and output (discharging) conditions. As a result of this testing, temperatures on temperature sensitive components shall not exceed the limits outlined in Table 16.1 and Table 16.2.

**Table 16.1**  
**Normal Temperature Limits – Component**

<b>Part</b>	<b>Maximum temperature (T<sub>max</sub>) °C (°F)</b>
Synthetic rubber or PVC insulation of internal and external wiring – without temperature marking  – with temperature marking	75 (167)  The temperature marking
Components, insulation, and thermoplastic materials	a
Cell casing	b
<p><sup>a</sup> Temperatures measured on components and materials shall not exceed the maximum temperature rating for that component or material including internal cells. <u>Temperatures measured on components and materials adjacent to cells shall not exceed the maximum temperature of 75° C (167° F).</u></p> <div data-bbox="162 840 1372 919" style="border: 1px solid black; padding: 5px; margin: 10px 0;"> <p>COMMENT: Adjacent component and material to cells should never reach above 75C. This may cause local heating on the cell to reach above 75 C.</p> </div> <p><sup>b</sup> The cell casing temperature shall not exceed the manufacturer's recommended maximum temperature and shall not exceed the maximum temperature of 75° C (167° F)</p> <div data-bbox="162 1071 1372 1150" style="border: 1px solid black; padding: 5px; margin: 10px 0;"> <p>COMMENT: Cell temperatures should never reach above 75 C regardless of manufacturer specs. It is unlikely that cells will be rated for above 75 C.</p> </div>	

**Table 16.2**  
**Normal Temperature Limits – Surface**

<b>Accessible surfaces</b>	<b>Maximum temperature (T<sub>max</sub>)</b>	
	<b>Metal °C (°F)</b>	<b>Plastic<sup>a</sup> °C (°F)</b>
Accessible parts held continuously during normal use	55 (131)	75 (167)
Accessible surfaces held or touched for short periods only	60 (140)	85 (185)
Accessible surfaces which may be touched	70 (158)	95 (203)
<sup>a</sup> Temperatures measured on accessible plastic enclosure surfaces shall not exceed the temperature ratings of the materials		

COMMENT: Table 16.2 While it is understandable that these temperatures are intended to reduce user burn hazards, a component that is generating these temperatures has the potential to make the environment unhealthy for the cells. Consider lowering the temperatures to protect the cells from adjacent heating sources.

16.2 For the output loading temperature test, a fully charged power bank shall be subjected to a constant resistive loading across the output ports of the power bank, at the maximum rated current of the output ports. Temperatures are monitored until thermal stabilization or until the built-in battery is at its rated endpoint voltage, whichever comes first.

16.3 For the input loading temperature test, a fully discharged power bank shall be subjected to charging at maximum current as specified by the manufacturer. Temperatures are monitored until thermal stabilization or until the built-in battery is at its fully charged state, whichever comes first.

16.4 Temperatures are considered to be stabilized when three successive readings taken at intervals of 10 % of the previously elapsed duration of the test, but not less than 15 min, indicate no further increase.

16.5 Protective devices within the pack shall not operate during the test.

16.6 Temperatures are monitored on surfaces of components using thermocouples. Thermocouples are to consist of 0.05 mm<sup>2</sup> (30 AWG) wires. Larger size wires may be used, but they shall not exceed 0.21 mm<sup>2</sup> (24 AWG) and shall not be large enough to result in a heat sink condition on the part under test.

16.7 During the normal temperature test, temperature measurement  $T$  shall not exceed:

$$\underline{T} = (T_{\max} + T_{\text{amb}} - T_{\text{ma}})$$

Where:

$T$  is the temperature of the given part measured under the prescribed test.

$T_{\max}$  is the maximum temperature specified for compliance with the test.

$T_{\text{amb}}$  is the ambient temperature during the test.

$T_{\text{ma}}$  is the maximum ambient temperature permitted by the manufacturer's specification, or 25 °C (77 °F), whichever is greater.

During the test  $T_{\text{amb}}$  should not exceed  $T_{\text{ma}}$  unless agreed by all parties involved.

## 17 Power Input Test

17.1 The current input to a power bank shall not exceed 110 % of the marked input current rating of the power bank, when the power bank is operated under the conditions of maximum normal load.

17.2 Maximum normal load shall consist of the maximum current draw while the power bank is operating in all possible modes including the battery at different states of charge. This may include charging the built-in battery, output ports unloaded or loaded at the rated maximum normal load and the operation of auxiliary functions such as flashlight, speaker, etc. Any load that can be operated at the same time shall be considered in order to obtain the maximum normal load.

## 18 Overload of Output Ports Test

18.1 Each power output pin of output port shall be overloaded in accordance with 18.2 – ~~18.6~~ 18.5.

18.2 In accordance with manufacturer's specifications, fully charge the built-in battery of the power bank.

18.3 The power bank is covered with one layer of cheesecloth and placed on a softwood board covered with one layer of tissue paper.

18.4 Each power output pin of output port shall then be loaded to draw the maximum current, for at least 1 h or the maximum duration of operation permitted by the battery pack, whichever is less.

18.5 During the test, the samples shall not vent, explode or catch fire.

COMMENT: The protective circuit for the output should keep the cells from overheating

~~18.5~~ 18.6 After this test, the cheesecloth and tissue paper shall remain intact.

## 19 Flammability of Photovoltaic Cells Test

19.1 This test shall be conducted if the power bank is provided with integral photovoltaic cells as a power source.

19.2 In accordance with manufacturer's specifications, fully charge the built-in battery of the power bank.

19.3 The power bank is covered with one layer of cheesecloth and placed on a softwood board covered with one layer of tissue paper.

19.4 The power bank is subjected to a single component fault that is likely to occur and which would result in flammability issue of the photovoltaic cells, such as back-feed of battery power, and is kept in this state for 1 h.

19.5 During this test, the battery shall not vent, explode or catch fire.

COMMENT: The test should not result in the cells from overheating

~~19.5~~ 19.6 After this test, the cheesecloth and tissue paper shall remain intact.

## 20 Capacity Verification Test

20.1 The marked electrical capacity of power bank, measured at the power output pin of output port, shall comply with IEC 61960-3, Clause 7.3.1, Discharge Performance at rated capacity (20 °C) ~~20 °C (Rated Capacity)~~ for lithium cell power bank or IEC 61951-2, Clause 7.3.2.3, Discharge performance for batteries at rated capacity (20 °C) ~~20 °C~~ for nickel cell power bank, and the modified test method in 20.2.

20.2 The power bank is discharged at a constant current equal to rated current of the output port, until its voltage is equal to the end-of-discharge voltage of the output port, specified by the manufacturer.

## ENCLOSURE TESTS

## 21 General

21.1 The power banks are to be tested in an ambient temperature of  $20 \pm 5$  °C ( $68 \pm 9$  °F).

21.2 Power banks shall be subjected to the tests described in Sections 22, 23, and 24, and 25. Power banks with outer enclosures made from materials other than plastic, shall be subjected to the tests described in Sections 22, 23 and 24 25.

## 22 Steady Uniform Force Test

22.1 The power banks are to be tested in an ambient temperature of  $20 \pm 5$  °C ( $68 \pm 9$  °F).

22.2 In accordance with manufacturer's specifications, fully charge the built-in battery of the power bank.

~~22.2~~ 22.3 External enclosures of the power bank are to be subjected to a steady force of  $250 \pm 10$  N ( $56 \pm 2$  lbf) for a period of 5 s, applied in turn to the top, bottom and sides of the power bank enclosure by means of a suitable test tool providing contact over a circular plane surface 30 mm (1.2 in) in diameter.

~~22.3~~ 22.4 The samples shall not explode or catch fire. The outer enclosure shall not crack to the extent that the cells or any protective devices are exposed. ~~Openings in the enclosure created as a result of application of the 250 N (56 lbf) steady force shall meet the criteria of 6.1.7.~~

22.5 The enclosure shall not separate as a result of application of the 250 N (56 lbf) steady force.

COMMENT: A permanently sealed housing should not separate under this test.

22.4 22.6 The sample shall be examined 6 h after testing and shall not flame, explode, vent or leak as described in 7.2.

## 23 Flexing Force Test

COMMENT: This test is reasonably foreseeable

23.1 Two power banks are to be tested in an ambient temperature of  $20 \pm 5$  °C ( $68 \pm 9$  °F). The samples shall not explode or catch fire or the outer enclosure shall not crack to the extent that the cells or any protective devices are exposed as a result of the forces applied in accordance with 23.5.

23.2 Each sample is to be tested in accordance with 23.3 through 23.6. The second sample shall be tested rotated 180° about its longitudinal axis from the orientation of the first sample.

Exception: Power banks with all external dimensions greater than 40 mm (1.6 in.) do not apply.

COMMENT: The exception was calculated from two 18650 (18 mm x 2 = 36 mm) cells side by side or stacked with 2 mm (2x 2mm = 4 mm) enclosure thickness.

23.3 In accordance with manufacturer's specifications, fully charge the built-in battery of the power bank.



23.3 Each of the two samples is to be tested according to 23.4. One sample shall be tested according to 22.4 and the second sample shall be tested in the same orientation as sample 1 but flipped (rotated 180°) as so the side facing down is facing upwards.

23.4 The test shall be set up as shown in Figure XX using a suitable test tool providing contact with the center rod through a flat plate such as a circular plane surface 30 mm (1.2 in) in diameter.

23.5 The power bank shall be placed with its longitudinal axis perpendicular to two 1/8-inch metal rods placed at opposite ends of the power bank; the center of the rod shall not be more than 1/4 inch from the edge of the enclosure. A 1/2-inch metal rod shall be placed on top of the power bank at the center of the longitudinal axis. The length of the metal rods shall be at least longer than the short axis of the power bank enclosure.

23.6 A linear force shall be applied to the center rod at a steady rate at 10 N/s  $\pm$ 2.5 N (2.25  $\pm$ 0.56 lbf) up to 250  $\pm$ 10 N (56  $\pm$ 2 lbf) and held for a period of 5 s.

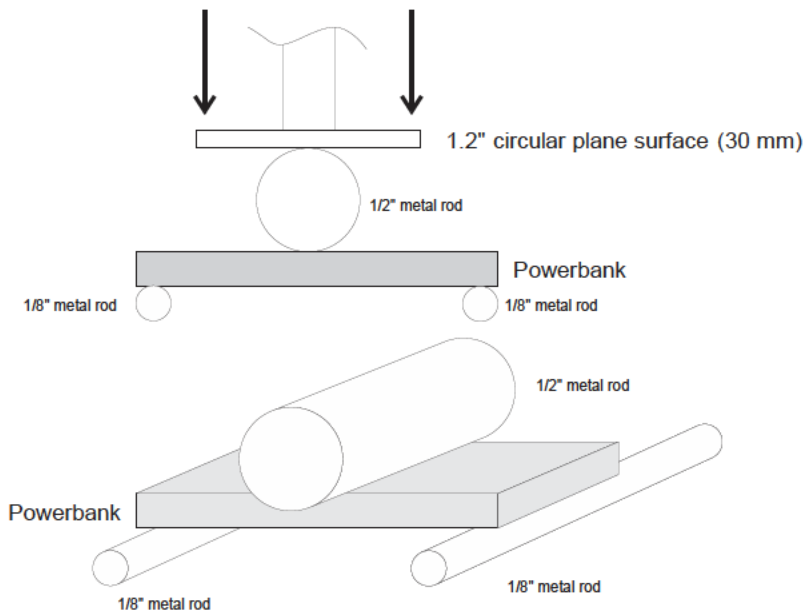

Figure XX. Flexing Force Test

23.6 The samples shall not explode or catch fire during the test. The outer enclosure is permitted to crack to the extent that the cells or any protective devices are not exposed. Openings in the enclosure created as a result of application of the 250 N (56 lbf) flexing force shall meet the criteria of 6.1.7.

23.7 The sample shall be examined 6 h after testing and shall not vent, flame, explode, or leak as described in 7.2.

### **23 24 Mold Stress Relief Test**

23.4 24.1 Each of three samples is to be placed in a full-draft circulating-air oven maintained at a uniform temperature of 70  $\pm$ 1 °C (158  $\pm$ 2 °F). The samples are to remain in the oven for 7 h.

*Exception: If the maximum temperature, T, recorded on the power bank thermoplastic enclosure parts, obtained during the normal temperature test of Section 16 exceeds 60 °C (140 °F), then the oven temperature is to be maintained at a temperature equal to T + 10 °C (50 °F).*

~~23.2~~ 24.2 To prevent hazards from overheating energized cells, samples shall either be fully discharged prior to conditioning or provided with "dummy" cells, which are representative of the actual cells.

~~23.3~~ 24.3 After careful removal from the oven and after returning to room temperature following the conditioning described in 24.1 ~~23.4~~, the samples shall show no evidence of mechanical damage that would result in damage to cells or protective circuitry. In addition, the enclosures shall not open or crack, warp, or melt to the extent that the cells or any protective devices are exposed.

## **24 ~~25~~ Drop Impact Test**

~~24.4~~ 25.1 The power banks are to be tested in an ambient temperature of  $20 \pm 5$  °C ( $68 \pm 9$  °F).

*Exception: Power banks employing plastic enclosures that are intended for use in a cold environment,  $\theta$  °C ( $32$  °F) temperatures less than 5 °C (41 °F), the sample shall be conditioned for 3 h at 0 °C (or the minimum temperature specified by the manufacturer if lower than 0 °C) prior to conducting the drop test, which shall be conducted immediately after removing the samples from the cold conditioning.*

COMMENT: The cold environment exception only specified one temperature, exactly 0 C. This allows all the other cold temperatures that are below 5 C to be tested at its rated cold temperature.

25.2 In accordance with manufacturer's specifications, fully charge the built-in battery of the power bank.

~~24.2~~ 25.3 Each of three samples is to be dropped from a height of 1 m (3.28 ft) so it strikes a concrete surface in the position that is most likely to produce the adverse results in 24.3. Each sample is to be dropped three times.

~~24.3~~ 24.4 The samples shall not vent, explode or catch fire.

~~24.4~~ 24.5 The sample shall be examined 6 h after testing and shall not vent or leak as described in 7.2, and the integrity of the protective devices shall be maintained.

~~24.5~~ 24.6 The outer enclosure and any covers relied on for compliance to this Standard shall not open or crack to the extent that cells or any protective devices are exposed. Any covers relied on for compliance to this Standard shall not separate or become detached.

## **25 ~~26~~ Label Permanence Test**

~~25.4~~ 26.1 The purpose of this test is to evaluate the permanence of an adhesive label that has not been subjected to a previous evaluation program. See 27.1 ~~26.4~~.

~~25.2~~ 26.2 An adhesive label secured to a surface representative of the end use application and is subjected to the following conditioning:

a) The label sample is rubbed by hand for 15 s with a piece of cloth soaked with water; and

b) The sample is again rubbed for 15 s with a piece of cloth soaked with petroleum spirit.

~~25.3~~ 26.3 The petroleum spirit to be used for the test is an aliphatic solvent hexane having:

a) A maximum aromatics content of 0.1 % by volume;

- b) A kauributenol value of 29;
- c) An initial boiling point of approximately 65 °C (149 °F);
- d) A dry point of approximately 69 °C (156.2 °F); and
- e) A mass per unit volume of approximately 0.7 kg/L.

*Exception: As an alternative, it is permitted to use a reagent grade hexane with a minimum of 85 % as n-hexane.*

~~25.4~~ 26.4 After the conditioning outlined in ~~26.2~~ 25.2, the sample is to be examined for signs of damage including curing and to determine if the marking is still legible. The sample is also examined to determine if it can be removed ~~by~~ easily by hand from the surface ~~the adhered surface~~.

~~25.5~~ 26.5 As a result of the conditioning, the sample label shall remain legible, show no evidence of damage including curling and shall not be able to be easily removed by hand from the adhered surface.

## MARKINGS

*Advisory Note: Markings required by this Standard may have to be provided in other languages to conform with the language requirements of the country or region where the product is to be used. In Canada, there are two official languages, English and French. Annex A provides translations in French of the English safety markings specified in this Standard.*

### **26** 27 General

~~26.1~~ 27.1 The markings required for compliance with this Standard shall be legible and permanent such as etched, adhesive labels, etc. An adhesive-backed label shall comply with the requirements in UL 969 or CSA C22.2 No. 0.15, for the intended exposure conditions and surface adhered to.

*Exception: Adhesive labels may be alternately evaluated to the Label Permanence Test in Section 25.*

~~26.2~~ 27.2 A power bank shall be legibly and permanently marked with:

- a) The manufacturer's name, trade name, or trademark or other descriptive marking by which the organization responsible for the product may be identified;
- b) A distinctive ("catalog" or "model") number or the equivalent;
- c) Input rating in Vdc or Vac with frequency, and A. If there is more than one input port, the rating of each port shall be provided. Symbol IEC 60417-5032 can be used for ac and symbol IEC 60417-5031 can be used for dc;
- d) Output rating in Vdc and A. If there is more than one output port, the rating of each port and the combined rating (if it is not equal to the summation of all ports) shall be provided;
- e) Electrical capacity in Ah or mAh. If there is more than one output port/output rating, either the capacity of each port/rating shall be provided, or the minimum capacity of these ports/ratings

shall be provided; and

f) The date or other dating period of manufacture not exceeding any three consecutive months.

*Exception No. 1: The manufacturer's identification may be in a traceable code if the product is identified by the brand or trademark owned by a private labeler.*

*Exception No. 2: The date of manufacture may be abbreviated; or may be in a nationally accepted conventional code or in a code affirmed by the manufacturer, provided that the code:*

*a) Does not repeat in less than 10 years; and*

*b) Does not require reference to the production records of the manufacturer to determine when the product was manufactured.*

~~26.3~~ 27.3 When a manufacturer produces the power bank at more than one factory, each power bank shall have a distinctive marking to identify it as the product of a particular factory.

~~26.4~~ 27.4 The following or equivalent wording shall be permanently and legibly marked on the power bank: "CAUTION: Risk of Fire and Burns. Do Not Open, Crush, Heat Above (manufacturer's specified maximum temperature) or Incinerate. Follow Manufacturer's Instructions." This wording or equivalent shall also be included in the instructions supplied with the power bank.

27.5 The markings shall be of contrasting colors or light versus dark of the enclosure, such that contrasting colors are those that sit opposite each other on the color wheel. Examples of contrasting color pairs are: Black and White, Red and green, Blue and orange, Yellow and purple.

COMMENT: This allows the markings to be legible. Printing black on black housing or white on white housing is difficult to read.

## INSTRUCTIONS

### ~~27~~ 28 General

~~27.1~~ 28.1 Power banks shall be provided with legible instructions pertaining to a risk of fire or injury to persons associated with the use of the product.

~~27.2~~ 28.2 An illustration is allowed with a required instruction to clarify the intent but shall not replace the written instruction.

~~27.3~~ 28.3 The following instructions shall be provided with the power bank in the form of a manual, stuffer sheet or on packaging. The instructions may additionally be repeated via markings provided directly on the power bank:

a) Instructions for operating and charging the power bank; and

b) Instructions for storing and disposing of the power bank.

## **28 29 Instructions Pertaining to Risk of Fire or Injury to Persons**

~~28.4~~ 29.1 Instructions pertaining to a risk of fire or injury to persons shall warn the user of reasonably foreseeable risks and state the precautions to be taken to reduce such risks. Such instructions shall be preceded by the heading "INSTRUCTIONS PERTAINING TO RISK OF FIRE OR INJURY TO PERSONS" or the equivalent.

~~28.2~~ 29.2 Unless otherwise indicated, the text of the instructions in 28.4 shall be in the words specified or words that are equivalent, clear, and understandable. Substitution of the signal word "DANGER" for "WARNING" is allowed when the risk associated with the product is such that a situation exists which, if not avoided, will result in death or serious injury.

~~28.3~~ 29.3 Numbering of the items in the list in 29.4 ~~28.4~~ and including other instructions pertaining to a risk of fire or injury to persons that the manufacturer determines to be necessary and that do not conflict with the intent of the instructions are acceptable.

~~28.3~~ 29.4 The instructions pertaining to a risk of fire or injury to persons shall include those items in the following list that are applicable to the product. The statement "IMPORTANT SAFETY INSTRUCTIONS" or the equivalent shall precede the list, and the statement "SAVE THESE INSTRUCTIONS" or the equivalent shall either precede or follow the list. The word "WARNING" shall be entirely in upper case letters or shall be emphasized to distinguish it from the rest of the text.

### IMPORTANT SAFETY INSTRUCTIONS

WARNING - When using this product, basic precautions should always be followed, including the following:

- a) Read all the instructions before using the product.
- b) To Reduce the Risk of Injury, close supervision is necessary when the product is used near children.
- c) Do not put fingers or hands into the product.
- d) Do not expose power bank to rain or snow.
- e) Do not expose power bank to heat or fire. Do not store in direct sunlight or in a vehicle.
- f) Use of a power supply or charger not recommended or sold by power bank manufacturer may result in a risk of fire or injury to persons.
- g) Do not use the power bank in excess of its output rating. Overload outputs above rating may result in a risk of fire or injury to persons.
- h) Do not use the power bank that is damaged or modified. Damaged or modified batteries may exhibit unpredictable behavior resulting in fire, explosion or risk of injury.
- i) Do not disassemble the power bank. Take it to a qualified service person when service or repair is required. Incorrect reassembly may result in a risk of fire or injury to persons.
- j) Do not expose a power bank to fire or excessive temperature. Exposure to fire or temperature above + °C may cause explosion. The temperature of + °C can be replaced by the temperature of + °F.

+ Shall be replaced with the temperature specified by the manufacturer.

k) Have servicing performed by a qualified service or repair person using only identical replacement parts. This will ensure that the safety of the product is maintained.

l) Switch off the power bank when not in use.

SAVE THESE INSTRUCTIONS

**Annex A (Normative for Canada and Informative for the US) – SAFETY MARKING TRANSLATIONS**

This Annex includes the markings required to be translated and suggested French translations. For Canada, this Annex is a normative (mandatory) part of this Standard. For the US, this Annex is an informative (non-mandatory) part of the Standard.

**Table A1.1**

**Safety Marking Translations**

Reference	English	French
15.6	"Limited Power Source"	« Source d'alimentation limitée »
<del>26.4</del> <u>27.4</u>	"CAUTION: Risk of Fire and Burns. Do Not Open, Crush, Heat Above (manufacturer's specified maximum temperature) or Incinerate. Follow Manufacturer's Instructions."	« AVERTISSEMENT : Risque d'incendie et de brûlures. Ne pas ouvrir, écraser, chauffer à une température supérieure à la température maximale indiquée par le fabricant ou incinérer. Suivre les instructions du fabricant. »
<del>28.4</del> <u>29.1</u>	"INSTRUCTIONS PERTAINING TO RISK OF FIRE OR INJURY TO PERSONS"	« INSTRUCTIONS RELATIVES AU RISQUE D'INCENDIE OU DE BLESSURE »

<p>28.4-29.4</p>	<p><b>“IMPORTANT SAFETY INSTRUCTIONS</b></p> <p><b>WARNING</b> - When using this product, basic precautions should always be followed, including the following:</p> <ul style="list-style-type: none"> <li>a) Read all the instructions before using the product.</li> <li>b) To Reduce the Risk of Injury, close supervision is necessary when the product is used near children.</li> <li>c) Do not put fingers or hands into the product.</li> <li>d) Do not expose power bank to rain or snow.</li> <li>e) Do not expose power bank to heat or fire. Do not store in direct sunlight or in a vehicle.</li> <li>f) Use of a power supply or charger not recommended or sold by power bank manufacturer may result in a risk of fire or injury to persons.</li> <li>g) Do not use the power bank in excess of its output rating. Overload outputs</li> </ul>	<p><b>« INSTRUCTIONS DE SÉCURITÉ IMPORTANTES</b></p> <p><b>AVERTISSEMENT</b> – Lors de l'utilisation de ce produit, les précautions de base doivent toujours être suivies, notamment :</p> <ul style="list-style-type: none"> <li>a) Lire toutes les instructions avant d'utiliser le produit.</li> <li>b) Pour réduire le risque de blessure, une surveillance étroite est nécessaire lorsque le produit est utilisé à proximité d'enfants.</li> <li>c) Ne pas insérer vos doigts ou vos mains dans le produit.</li> <li>d) Ne pas exposer le chargeur portatif à la pluie ou à la neige.</li> <li>e) Ne pas exposer le chargeur portatif à la chaleur ou au feu. Ne pas laisser en plein soleil ou à l'intérieur d'un véhicule.</li> <li>f) L'utilisation d'un bloc d'alimentation ou d'un chargeur non recommandé ou non vendu par le</li> </ul>
------------------	--	---

Reference	English	French
	<p>above rating may result in a risk of fire or injury to persons.</p> <p>h) Do not use the power bank that is damaged or modified. Damaged or modified batteries may exhibit unpredictable behavior resulting in fire, explosion or risk of injury.</p> <p>i) Do not disassemble the power bank. Take it to a qualified service person when service or repair is required. Incorrect reassembly may result in a risk of fire or injury to persons.</p> <p>j) Do not expose a power bank to fire or excessive temperature. Exposure to fire or temperature above + °C may cause explosion. The temperature of + °C can be replaced by the temperature of + °F. + Shall be replaced with the temperature specified by the manufacturer.</p> <p>k) Have servicing performed by a qualified service or repair person using only identical replacement parts. This will ensure that the safety of the product is maintained.</p> <p>l) Switch off the power bank when not in use.</p> <p>SAVE THESE INSTRUCTIONS"</p>	<p>fabricant de chargeurs portatifs peut entraîner un risque d'incendie ou de blessure.</p> <p>g) Ne pas utiliser le chargeur portatif au-delà de sa puissance nominale de sortie. Cela pourrait entraîner un risque d'incendie ou de blessure.</p> <p>h) Ne pas utiliser un chargeur portatif endommagé ou modifié. Les batteries endommagées ou modifiées peuvent adopter un comportement imprévisible qui représente un risque d'incendie, d'explosion ou de blessure.</p> <p>i) Ne pas démonter le chargeur portatif. En confier la réparation ou l'entretien à un technicien qualifié le cas échéant. Un réassemblage inapproprié pourrait entraîner un risque d'incendie ou de blessure.</p> <p>j) Ne pas exposer le chargeur portatif au feu ou à une température excessive. L'exposition au feu ou à une température supérieure à + °C peut provoquer une explosion. La température de + °C peut être remplacée par une température de + °F. La valeur + doit être remplacée par la température spécifiée par le fabricant.</p> <p>k) Pour l'entretien, communiquer avec un technicien ou un réparateur qualifié qui n'utilise que des pièces de rechange identiques. Cela assurera l'intégrité de la sécurité du produit.</p> <p>l) Éteindre le chargeur portatif lorsqu'il n'est pas utilisé.</p> <p>CONSERVER CES INSTRUCTIONS »</p>