



**U.S. Consumer Product Safety Commission
4330 East West Highway
Bethesda, MD 20814**

Nicotine Packaging Test Parameters

March 8, 2019

Dear Sir or Madam:

The Child Nicotine Poisoning Prevention Act of 2015 (CNPPA), Pub. L. No. 114-116, requires nicotine provided in a liquid nicotine container sold, offered for sale, manufactured for sale, distributed in commerce, or imported into the United States to be in "special packaging," as defined by the Poison Prevention Packaging Act, 15 U.S.C. § 1471(4), in accordance with the standard provided at 16 C.F.R. § 1700.15. As noted in my February 20, 2019 letter to industry, CPSC staff had not previously provided guidance with respect to compliance with specific provisions of 16 C.F.R. § 1700.15.

Attached please find the testing parameters that the CPSC staff will use to assess compliance with the restricted flow requirement in 16 C.F.R. § 1700.15(d). You may use this test protocol or an equivalent testing method to determine compliance. It is your responsibility to ensure that your products meet all of the applicable packaging requirements under the CNPPA and 16 C.F.R. § 1700.15. In addition, section 14(a)(1) of the Consumer Product Safety Act, 15 U.S.C. § 2063(a)(1), requires that manufacturers of such liquid nicotine containers issue a General Certificate of Conformity that the products meet those requirements.

We appreciate your continued cooperation in meeting the CNPPA packaging requirements for liquid nicotine. If you have any questions, please contact Compliance Officer Stephen Lee at 301-504-7844, or by email at slee@cpsc.gov.

Sincerely,

A handwritten signature in blue ink, appearing to read "Robert S. Kaye".

Robert S. Kaye
Director
Office of Compliance and Field Operations

Attachment: Nicotine Flow Restriction: CPSC Staff's Test Methodology dated March 6, 2019



**United States CONSUMER PRODUCT SAFETY COMMISSION
4330 East West Highway, Bethesda MD 20814**

March 6, 2019

Nicotine Flow Restriction: CPSC's Test Methodology

The Child Nicotine Poisoning Prevention Act of 2015 (CNPPA), Public Law No. 114-116, was enacted on January 28, 2016, requiring "any nicotine provided in a liquid nicotine container, sold, offered for sale, manufactured for sale, distributed in commerce, or imported into the United States shall be packaged in accordance with the standards" of the Poison Prevention Packaging Act (PPPA) in 16 CFR § 1700.15, as determined through testing in accordance with the methods described in 16 CFR § 1700.20.

The CNPPA requires compliance with the Commission's regulation 16 CFR § 1700.15. This includes the restricted flow requirement stated in paragraph (d) of that section. The regulation requires "special packaging . . . from which the flow of liquid is so restricted that not more than 2 milliliters of the contents can be obtained when the inverted, opened container is taken or squeezed once or when the container is otherwise activated once." 16 CFR § 1700.15(d).

This document describes the methodology CPSC staff intends to use to test liquid nicotine containers for compliance with the restricted flow provisions at 16 CFR § 1700.15(d). When developing this test methodology, staff considered the PPPA's provisions and the recent draft ASTM F02 Committee's *Standard Test Method for Assessing Non-Metered Restricted Delivery Systems for Liquid Consumer Products*, Application of Force method. Staff's test methodology simulates a 5-year-old child gripping an inverted bottle for five seconds. It uses the maximum measured thumb diameter, 95th percentile palm width, and a 95th percentile five-point pinch strength.

1. Test Method Overview

This test method describes how CPSC staff will assess special packaging for liquid nicotine containers subject to 16 CFR § 1700.15(d), which requires "...the flow of liquid [to be] so restricted that not more than 2 milliliters of the contents can be obtained when the inverted, opened container is taken or squeezed once or when the container is otherwise activated once." The test fixture described below is designed to determine the amount of liquid released from the test container when squeezed once while inverted. The following is an overview of the test method.

A mechanical squeeze action is produced through an anthropometry-based simulation of a thumb and palm breadth plus a five-point pinch (thumb vs four fingers) force for a 5-year-old child. Referring to Figure 1, the test container is inverted in the test sample holder by the thumb and palm gripping components. The test force is applied perpendicularly to the test container through a weight and pulley/cable arrangement and pivot points (P). The test begins by release of the latch upward. Liquid is allowed to dispense for five seconds and collected in a container below the inverted test container. The masses of the test container before and after testing are used to

determine the mass of dispensed liquid. Volume dispensed is determined by a volume/mass ratio determined by sampling prior to testing. The volume dispensed is compared to the maximum two ml limit stated in 16 CFR § 1700.15(d) to determine compliance with that requirement.

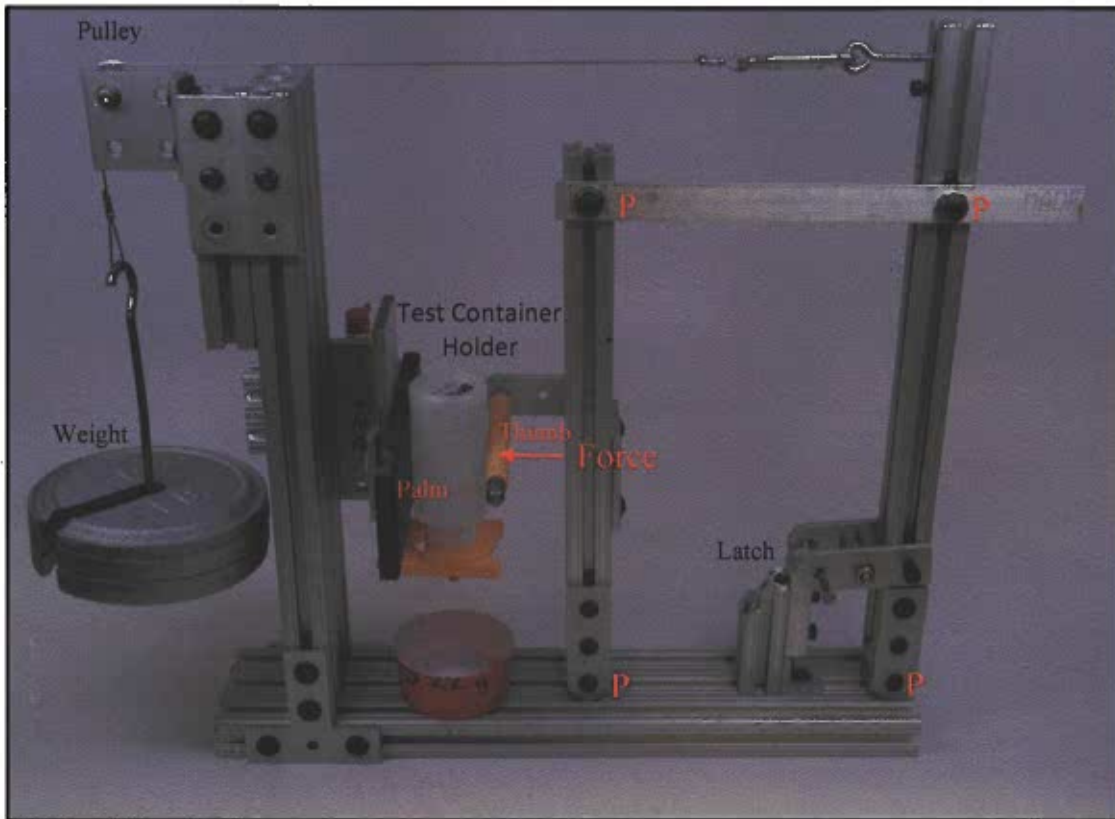

Figure 1. Image of Squeeze Test Fixture

2. Test Equipment Description

Table 1: Test Equipment Requirements and Key to Figures

Key	Description	Requirement	Figure
A	Weight	Approximately 5.6 lb (2.5 kg) of weight, adjusted as needed to obtain the required force	2
B	Cable	0.047" (1.2 mm), 7-19 strand, stainless steel	2
C	Pulley	1" to 1.5" (25 to 38 mm) diameter ball bearing	2
D	Pivot Frame	Aluminum (recommended)	2
E	Link	Aluminum (recommended)	2
F	Latch	Holds D and L vertically prior to release	2
G	Pivot (1 of 4)	0.25 in (6.35 mm) diameter (maximum) solid bearing	2
H	Palm Grip	2.36 +/- .01 in (60 +/- 0.25 mm) width x 4 in (101 mm) long; any rigid, machinable material	2, 3, 4
I	Test Container		
J	Thumb Grip (thumb diameter)	Metal, and may have a durable plastic sleeve, with combined outer diameter 0.55 + .01/-0.00 in (14 +0.25/-0.0 mm) diameter by 3 in (76 mm) (minimum) long.	2, 3
K	Fixed Frame	Aluminum (recommended)	2
L	Pivot Frame	Aluminum (recommended)	2
M	Test Container Support		2, 3
N	Load Cell	Nominally 100-250 N, (20-50 lbf) 0.25% accuracy full scale	5
D/J	Leverage Ratio	$15.0/7.5 = 2:1$ ratio is recommended	2

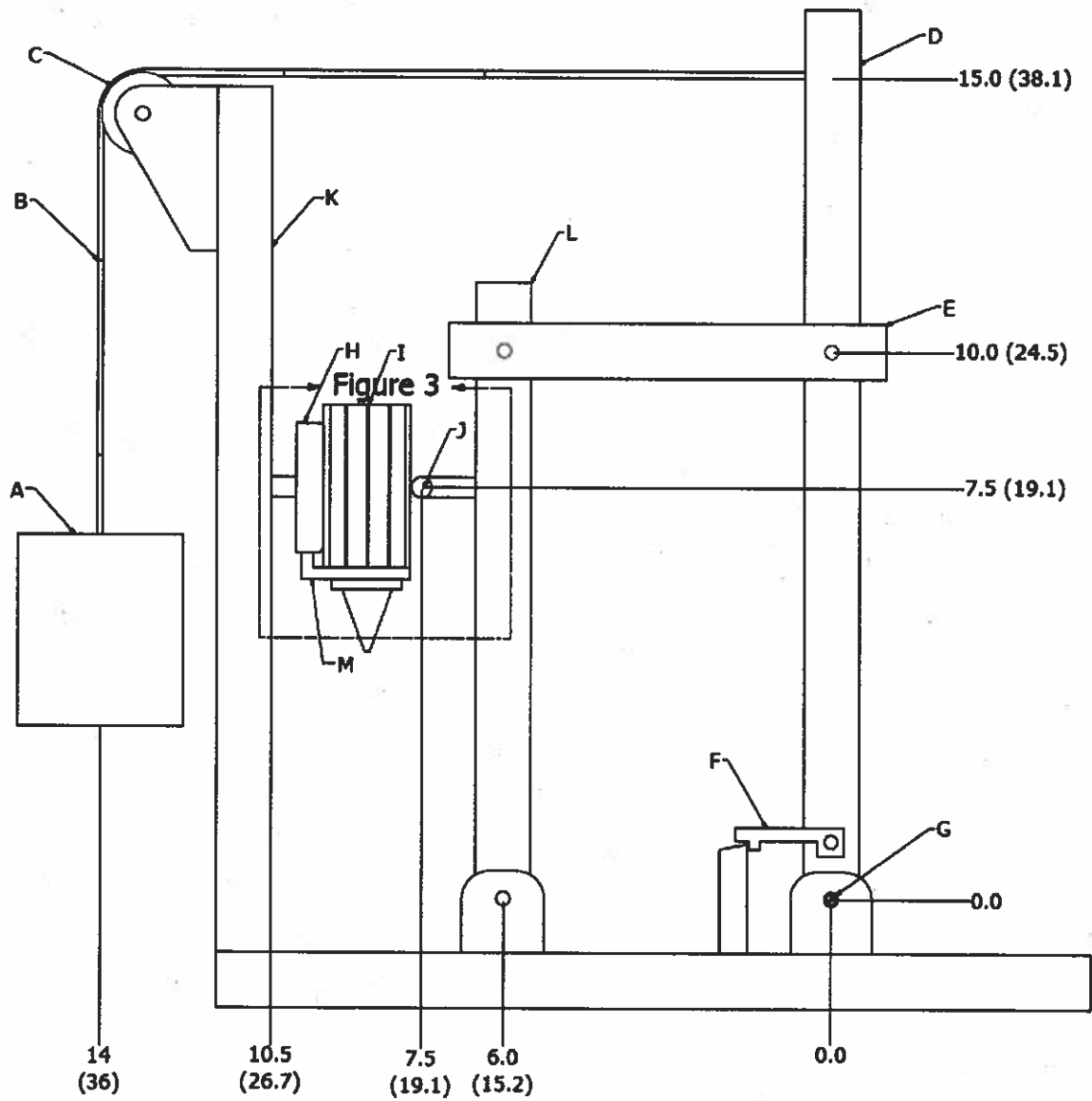

Figure 2. Drawing of Test Fixture -Side View
 (Dimensions are inches (cm) from reference at G)

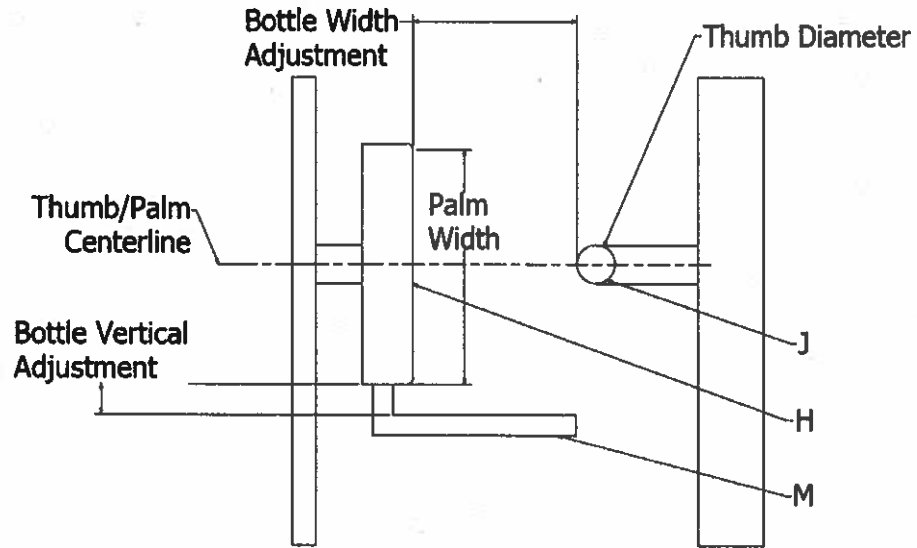

Figure 3. Detail- Container Holder

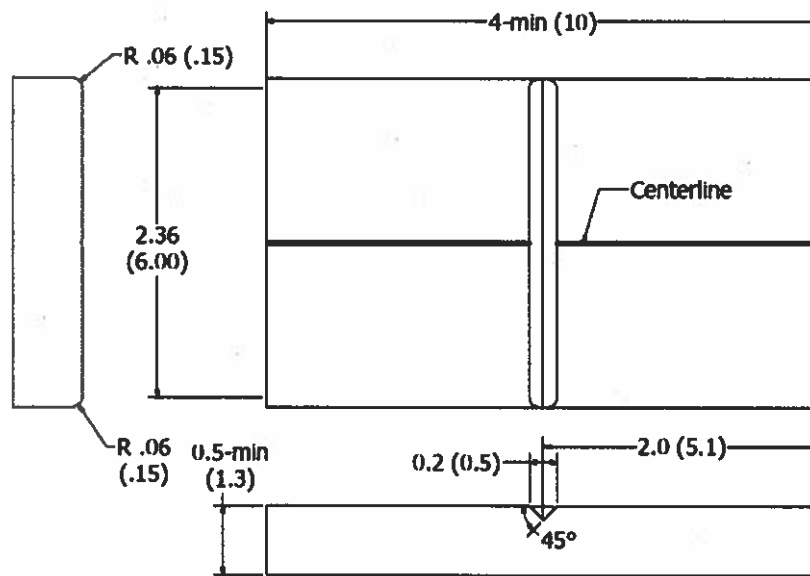

Figure 4. Palm Grip Dimensions, inches (cm)

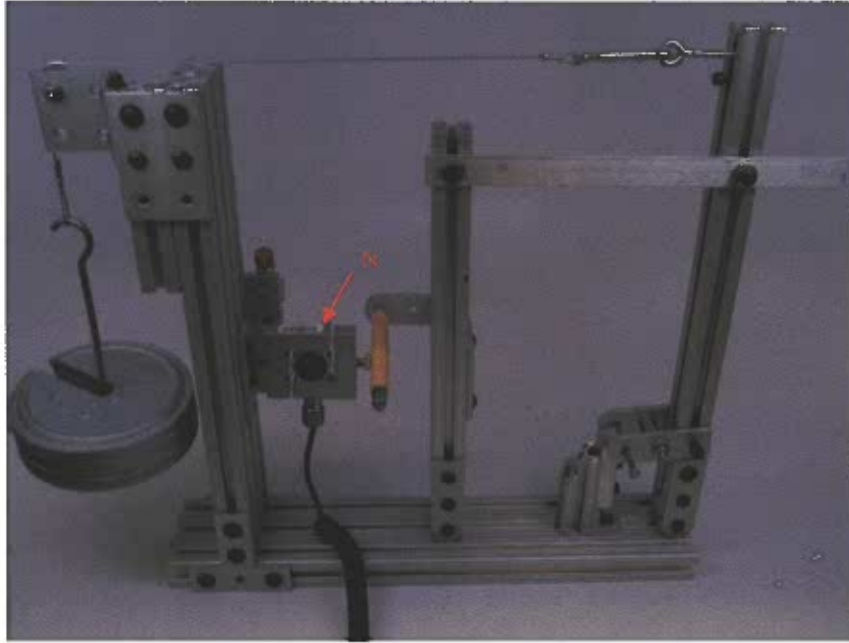

Figure 5. Calibration of Squeeze Test Fixture

3. Test Procedure: Application of Force

Figures 1 through 5 are used in describing the following test procedure. Mass shall be determined to an accuracy of ± 0.05 g (0.0001 lb). Volume shall be determined to an accuracy of ± 0.05 ml (0.002 fl oz). Force shall be determined to an accuracy of ± 0.1 lbf (0.4 N).

1. Prepare the test container.
 - a. For empty containers.
 - i. Fill the test container to 90 \pm 5% capacity with a placebo with a viscosity similar to a liquid nicotine product; or
 - ii. Fill the test container to 90 \pm 5% capacity with water.
 - b. For containers supplied with liquid (e.g. retail). Record the approximate percentage \pm 5% of liquid volume to container volume.
 - i. Liquid Volume _____ %
 - c. Note whether the container leaks any fluid when inverted without squeezing.
 - i. Did the container drip when inverted? _____ Yes/No
2. Determine the mass of the test container prepared in step 1.
 - a. Test Container Mass _____ g.
3. Remove a 2 \pm 0.5/-0 ml (0.07 \pm 0.02/-0 fl oz) sample of liquid from the test container (using oral syringe or squeezing into dosing cup), then determine the remaining mass of the test container.
 - a. Sample volume _____ ml
 - b. Test Container mass less sample mass _____ g.
 - c. Note: This sample is used to determine density.

4. Determine the sample density as the mass difference from steps 2 and 3 divided by the sample volume (ml):
 - a. Mass difference, $2a - 3b$ _____ g.
 - b. Sample density, $4a/3a$ _____ g/ml.

5. Calibrate the test fixture for 11.2 lbf (50 N). Refer to Figure 5.
 - a. Install the load cell (N) in place of the palm grip (H).
 - b. Adjust the force transducer position to the centerline of the thumb grip (J) and with the pivot frame (L) vertical.
 - c. Place weights until the transducer reads 11.2 lbf (50 N).
 - d. Replace the palm grip.
 - e. Calibration is recommended before and after each test series, or each day.

6. Secure the test container in the test container holder.
 - a. Mark the vertical midpoint of the test container. This is the mid-point distance between the bottom and shoulder of the container.
 - b. Close the container dispenser from potentially leaking when inverted.
 - i. Use the dispensing closure device for containers that have one.
 - ii. For containers without a dispenser closure (e.g. needle), temporarily place a suitable cap over the exit point such that no liquid is dispensed prior to the test.
 - c. Apply Latch (F) to pivot frame (D).
 - d. Adjust the palm grip (H) and the container support (M),
 - i. So that the palm grip midpoint aligns with the container midpoint mark, and
 - ii. So that the container sits in the vertical groove of the palm grip and is in (light) contact with the thumb grip (J).

7. Prepare to receive the liquid from the test container.
 - a. Place a collection cup beneath the test container.
 - b. Open the dispenser closure or remove the temporary cap.
 - c. If the container dripped in step 1c, hold a small receptacle (e.g. spoon) against the container nozzle to prevent any drips.

8. Start the test.
 - a. Hold the pivot frame (D) and release the latch (F) by moving upward.
 - i. Remove the drip catcher (e.g. spoon) and start test before the container drips. One drip is acceptable.
 - ii. Release the pivot frame over a 1 second interval to allow the thumb grip to gradually load the test container.
 - iii. Release the pivot frame completely and allow the test container to be squeezed for a total of 5 seconds, including the initial 1 second interval.
 - b. Immediately relieve force on the container and re-latch to pivot frame (D).
 - c. Close the container or replace the temporary cap.

9. Determine the amount of liquid dispensed.
 - a. Determine the difference in mass before and after testing.
 - i. Remove any temporary cap.
 - ii. Mass of test container after liquid is dispensed _____ g.
 - iii. Mass of test container before liquid is dispensed _____ g. (step 3b)
 - b. Subtract iii - ii. Dispensed= _____ g.
 - c. Determine the volume dispensed as mass dispensed divided by density.

- i. Mass dispensed _____ g. (step 9b)
- ii. Density _____ g/ml (step 4b)
- iii. Volume Dispensed _____ ml (9c(i)/9c(ii))

10. Report

- a. Volume dispensed with pass/fail criteria.
 - i. Whether the volume dispensed ≤ 2 ml (met 16 CFR § 1700.15(d)), or
 - ii. Whether the volume dispensed > 2 ml (did not meet 16 CFR § 1700.15 (d)).
- b. Whether the container when inverted dripped with no side load.
- c. Whether the test container was tested as received, filled with a placebo, or filled with water.
 - i. If filled with a placebo, what were the contents and the mixture?
- d. The initial percentage of liquid volume to container volume.

4. References for Anthropometric Data

1. Thumb Diameter of a 5 year old male at the distal phalanx: The median is 0.51 inches with a range from 0.47 to 0.55 inches. Staff recommends using the maximum value measured, which is 0.55 inches, for the diameter of the rod that simulates the thumb on the test fixture.

Reference: Hohendorff, B., Weidemann, C., Burkhart, K.J., Rommens, P. M., Prommersberger, K.J., Konerding, M.A. (2010). Lengths, girths, and diameters of children’s fingers from 3 to 10 years of age. *Annals of Anatomy*, 192, 156-161.

2. Hand breadth at the palm of a 4.5-5.5 year old male and female: the mean is 2.1 inches whereas 95th percentile value is 2.36 inches. Staff recommends using the 95th percentile value, which is 2.36 inches, for the width of the base plate that simulates the four fingers on the test fixture.

Reference: Owings, C.L, Norcutt, R. H., Snyder, R. G., Golomb, D. H., Lloyd, K.Y. (1977). Gripping strength measurements of children for product safety design. University of Michigan prepared for the Consumer Product Safety Commission, Contract CPSC-C-76-0119.

3. Squeeze Force: Thumb pad vs four finger pads: Staff recommends using 11.22 pounds force as the squeeze force that corresponds to the strength of 95th percentile 4.5-5.5 years old M/F when the distance between thumb and four fingers is 5 cm.

Reference: Owings, C.L, Norcutt, R. H., Snyder, R. G., Golomb, D. H., Lloyd, K.Y. (1977). Gripping strength measurements of children for product safety design. University of Michigan prepared for the Consumer Product Safety Commission, Contract CPSC-C-76-0119.